

V 1.0 - 102024



## PeopleLink Speaker Track Pro

### key Features

- 1/2.8" CMOS, 2.14MP
- 12x optical zoom, up to 72.5° FoV
- Simultaneously output 3G-SDI, HDMI, Ethernet, up to 1080P60 resolution
- Support H.264 / H.265 video compression
- Implemented with both audio positioning body recognition technologies, it can precisely frame the speaker(s)
- Automatically switch between close-up image for speaker(s) and wide-angle image for all attendees
- Built-in image according to meeting scenarios

[Watch Video !\[\]\(17413706fd4997a1a4bdf85c6864eee1\_img.jpg\)](#)

PeopleLink Speaker Track camera helps to achieve an intelligent meeting experience, and it is implemented with both audio positioning and intelligent video analysis technologies. It can automatically switch between a close-up image and a full-view image to frame the speaker(s). This frees up camera operation during a meeting and enables meeting attendees to focus more on discussion.

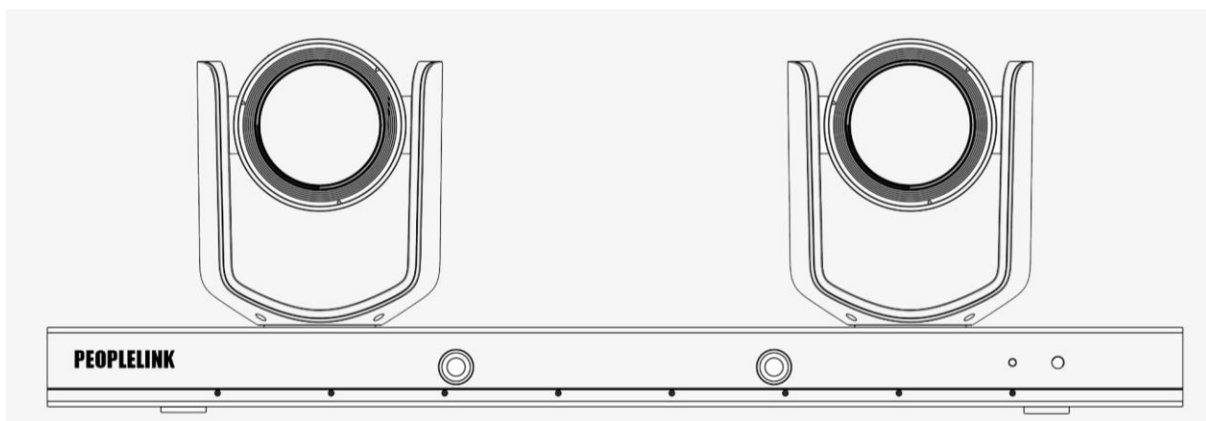

## General Specifications

### Camera

- Image Sensor** : 1/2.8" CMOS, 2.14MP
- Signal Format (SDI)** : 1080P60, 1080P50, 1080P30, 1080P25, 1080I60, 1080I50, 720P60, 720P50
- Focal length** : 3.9mm-46.8mm
- Iris** : F1.6-F2.8
- Optical Zoom** : 12x
- Digital Zoom** : 12x
- Field of View** : 72.5°-6.3°
- Focus** : Auto, Manual, PTZ Push, One Push
- Min. Illumination** : 0.5 Lux (Color), 0.1 Lux (B/W)
- Shutter Speed** : 1/25-1/10,000s
- AGC** : Auto/Manual
- White Balance** : Auto, Indoor, Outdoor, One Push Manual, Auto Track
- AE Control** : Auto, Manual, Shutter Priority, Iris Priority
- S/N** : ≥50dB
- DNR** : 2D/3D
- BLC** : Support
- Pan Range** : 90°~+90°
- Tilt Range** : -30°~+90°
- Pan Speed** : 0.1°~120°/s
- Tilt Speed** : 0.1°~80°/s
- Preset Number** : 255
- OSD** : Yes
- Image Flip** : Yes

### Network

- Max. Image Size** : 1920 × 1080 @60 fps
- Video Compression** : H.265,H.264
- Audio Compression** : AAC
- Protocol** : HTTP, RTSP, RTMP, RTP, TCP, UDP, ONVIF
- Dual Stream** : Support

### Interface

- Video Output** : 1 × HDMI Interface, 1×3G-SDI Interface
- Audio Input** : 2 × LINE IN, including one channel with EC
- Audio Output** : 1 × LINE OUT
- Network Interface** : 1 × 10M/100M
- USB Interface** : 1 × USB2.0
- Control Interface** : 1 × RS-232

### General Specifications

- Control Protocol** : VISCA, PELCO-P, PELCO-D
- Address** : 0~63
- Power Supply** : DC12V
- Power Consumption** : <50W
- Working Temp** : 0°C ~ + 40°C
- Storage Temp** : -20°C ~ +60°C
- Dimension (LxWxH)** : 500 mm x 162mm x 137mm
- Weight** : 3kg



## Application Scenarios

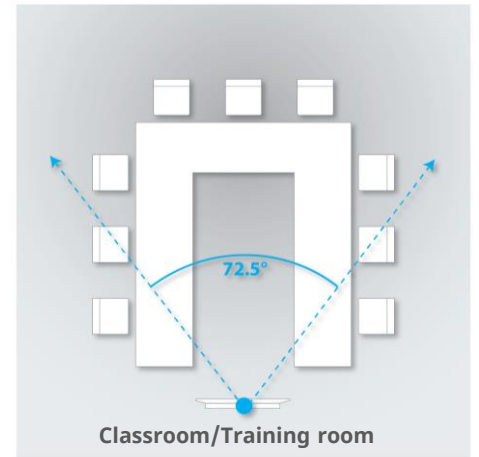
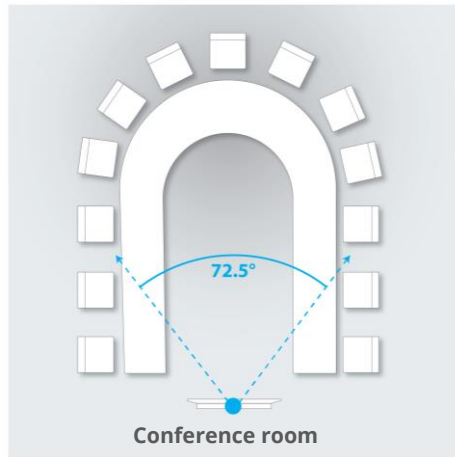
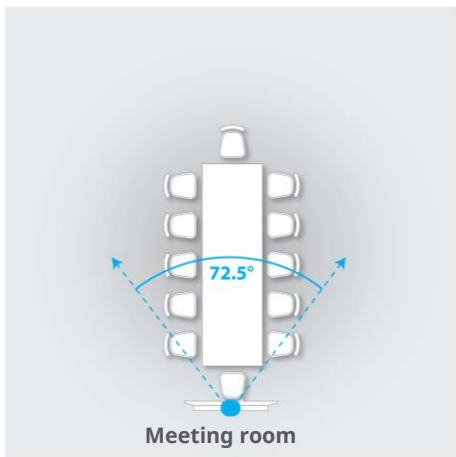

**Disclaimer:-** Room setup diagrams are provided for reference only. Actual room setup and size may vary as per requirements.

## Connectivity

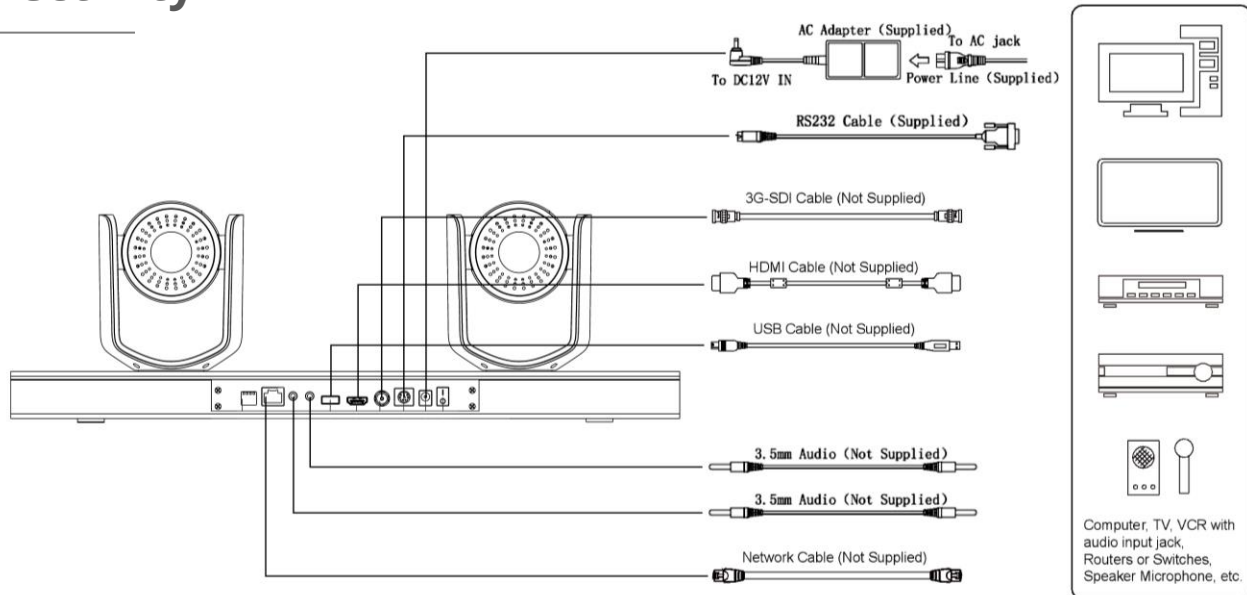

## Ordering Information

Speaker Track Pro Camera  
Dual motorized PTZ Camera with HDMI Capture Card

: **PEP-PIS-STP**

Speaker Track Standard Camera  
Dual motorized PTZ Camera without HDMI Capture Card

: **PEP-PIS-STS**

**LEARN MORE**

For more information on Speaker Track Pro [Click Here](#)

## SALES AND INQUIRIES

### Global Headquarters

Q3-A3, 10th Floor Cyber Towers,  
HITEC City, Hyderabad,  
Telangana 500081, **India**  
**Phone:** +91 9100123013  
**Email:** vc@peoplelinkvc.com

### International Contact Numbers

**USA:** +1 669-696-8383  
**Australia:** +61 370 037070  
**France:** +33 6 80 75 26 42  
**Middle East:** +966 5300 19292  
**UK:** +44 20 4571 5454

**UAE:** +971 4 3339082  
**Canada:** +1 647-945-7373  
**Malaysia:** +(6)018-2872188  
**New Zealand:** +64-9-802-4666  
**Africa:** +254 107 529 656

### Tech Support

**Toll Free:** 1800 208 3399  
customersupport@peoplelinkvc.com